



MUSTANG
EQUIPMENT

MODEL DCHD, ELECTRIC-HYDRAULIC GATE OPENER

The Model DCHD Gate Opener utilizes an on-board 24 volt battery system to operate the hydraulic power unit, also on-board. It provides 1,600 ft-lbs of power at 8 RPM.

All Mustang Equipment Gate Openers come with the following standard features:

- We are the first in the market to offer a heavy wall aluminum tube frame that provides a strong, light weight, corrosion resistant design. All stainless steel fasteners and a powder coat finish provides you with the highest corrosion resistant design on the market.
- Stable 3 wheel design for easy maneuvering and use. The front two wheels are fixed while the third is a swiveling caster. Fold down stabilizers for high torque situations.
- Pivoting front wheels for traveling capstans. A single lever rotates the front wheels 90 degrees. Front wheels lock in the forward or pivoted position.
- Vertically adjustable output shaft allows for variations between different gate heights and unloading platforms. shaft height can be adjusted anywhere between 6 and 20 inches above the ground.
- Hardened steel output shaft provides high strength as well as resistance to fatigue and stress. It is precision machined and easily changed if worn or damaged.
- Flat free solid tires of cushion rubber on high-impact polypropylene wheel centers. These tires are ideal for outdoor use and compliment our corrosion resistant design.

The MODEL DCHD Gate Opener comes standard with two 12 volt, 200 cca marine type batteries wired in series. Batteries are housed in protective battery boxes.



Model DCHD Operating Weight = 200 lbs

Hydraulic operation of drive train lift available as an option.

Different shaft lengths are available on request.



MODEL DCHD, ELECTRIC-HYDRAULIC GATE OPENER

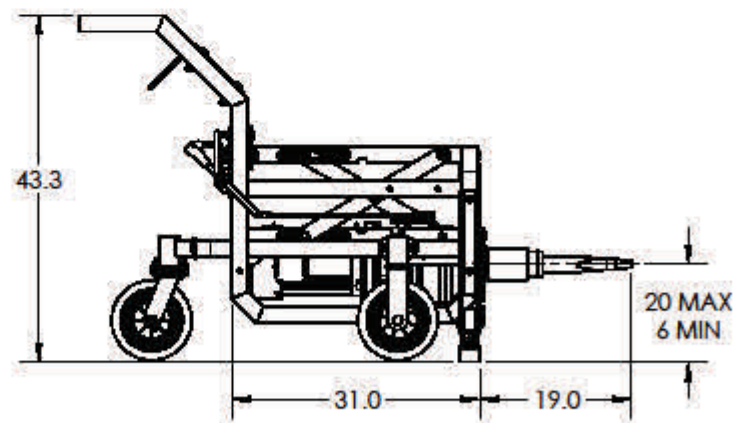
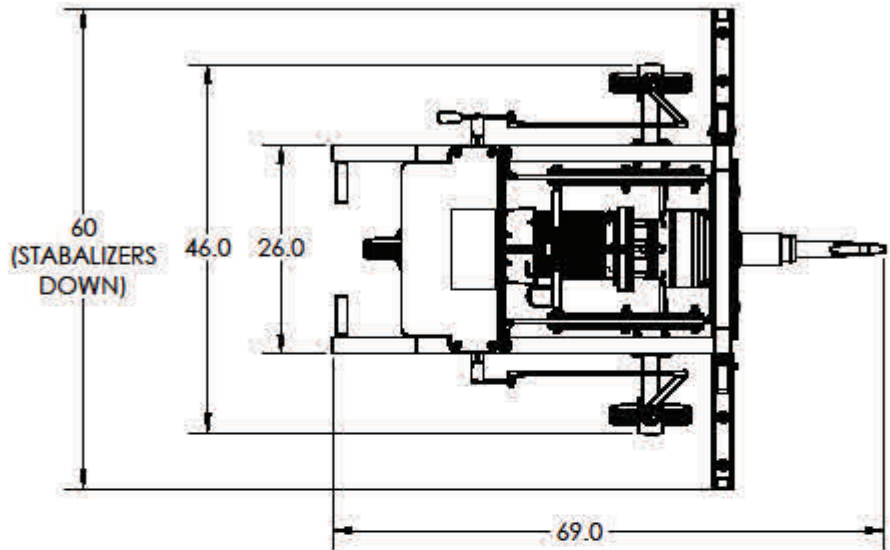

We offer a full line of electric, hydraulic and pneumatic hopper gate openers. Contact us today.

mustang-equipment.com | 314-270-4000 | info@mustang-equipment.com